

R3C FEMALE HOUSING

R197.115._80

Series : **SMB CARLOCK**

To obtain the complete P/N please fill in the blank "_" with the coding letter

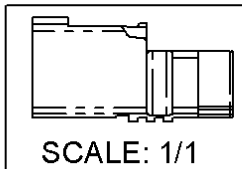
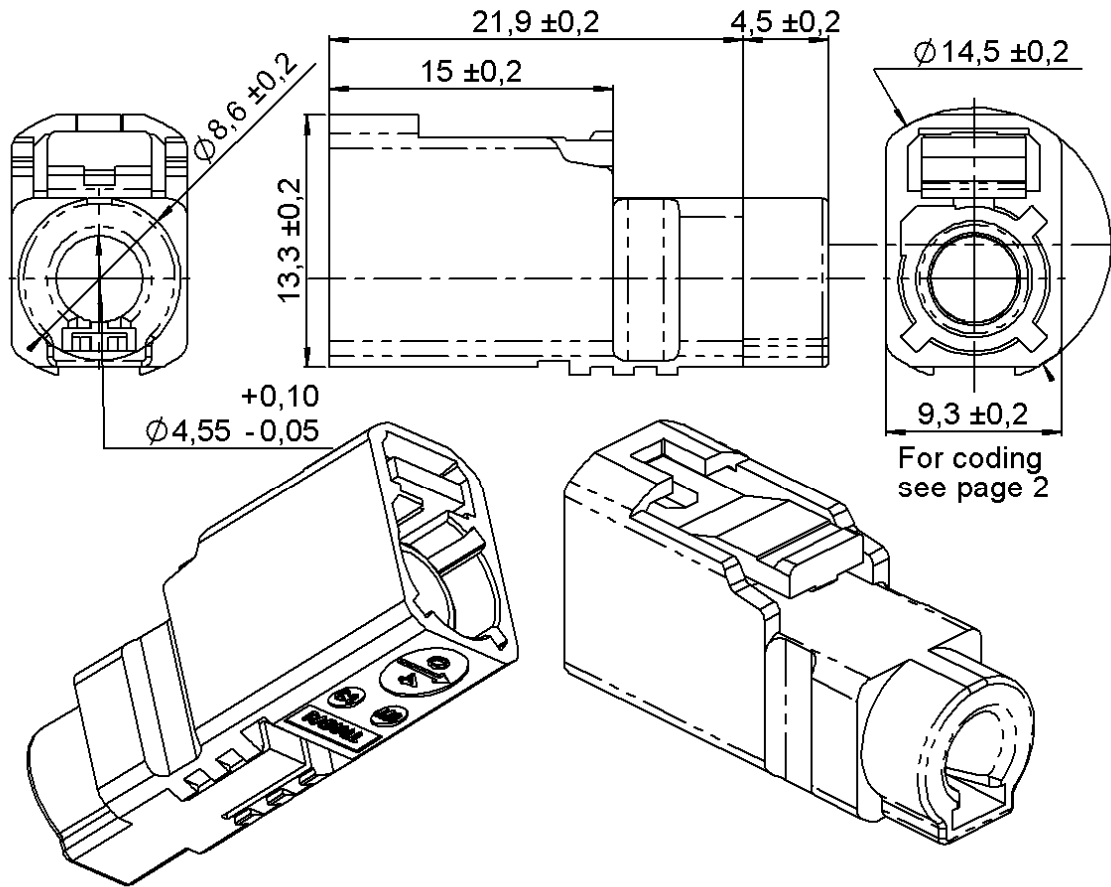

Housing to be used with:
 -R299.197.200
 -R299.197.210

All dimensions are in mm.

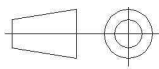
COMPONENTS	MATERIALS	PLATING  (µm)	
		UL CLASSIFICATION	COLOR
HOUSING	PA6.6 GF15 (POLYAMIDE)	UL 94 V-2	See Page2

PACKAGING

Standard 4800	Other Contact us
-------------------------	----------------------------

MECHANICAL CHARACTERISTICS

ENVIRONMENTAL

Mating life **100** Cycles mini
 Weight **1,6500** g

Operating temperature **-40/+110 °C**

Issue : 1609 A

In the effort to improve our products, we reserve the right to make changes judged to be necessary.



R3C FEMALE HOUSING

R197.115._80

Series : SMB CARLOCK

-To obtain the complete P/N please fill in the blank "_ " with the coding letter

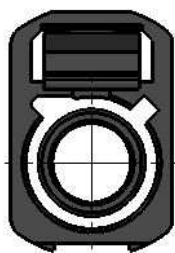

A

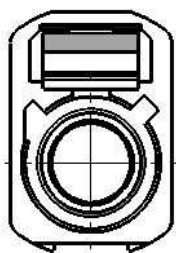

B

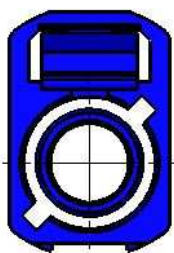

C

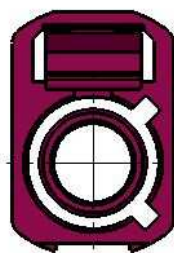

D

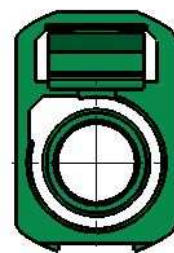

E

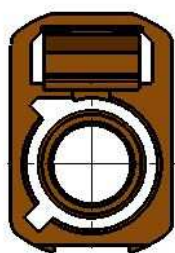

F

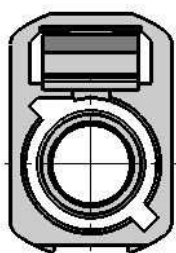

G

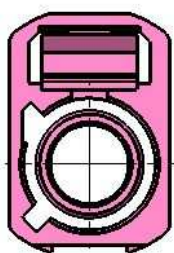

H

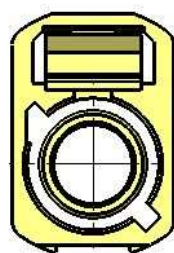

I

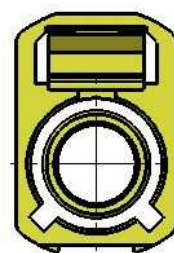

K



L

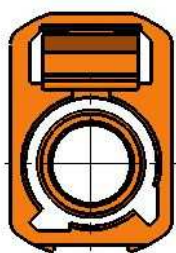

M

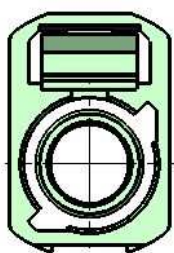

N

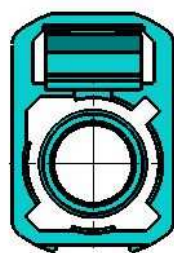

Z

Code	Color	RAL	RAYDIALL reference
A	Black	9005	R197.115.A80
B	Creme white	9001	R197.115.B80
C	Blue	5005	R197.115.C80
D	Bordeaux	4004	R197.115.D80
E	Green	6002	R197.115.E80
F	Brown	8011	R197.115.F80
G	Grey	7031	R197.115.G80
H	Violet	4003	R197.115.H80
I	Beige	1001	R197.115.I80
K	Curry	1027	R197.115.K80
L	Carmin	3002	R197.115.L80
M	Pastel orange	2003	R197.115.M80
N	Pastel green	6019	R197.115.N80
Z	Water blue	5021	R197.115.Z80

Issue : 1609 A

In the effort to improve our products, we reserve the right to make changes judged to be necessary.

R3C FEMALE HOUSING

R197.115._80

Series : SMB CARLOCK

RECOMMENDED MOUNTING PROCEDURE

1

● **Pre-insertion of the coax into the housing**

● **Orientation of the tab of the coax with the slot of the housing.**

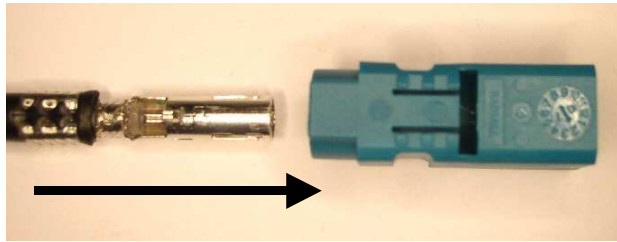

Orientation of the slot

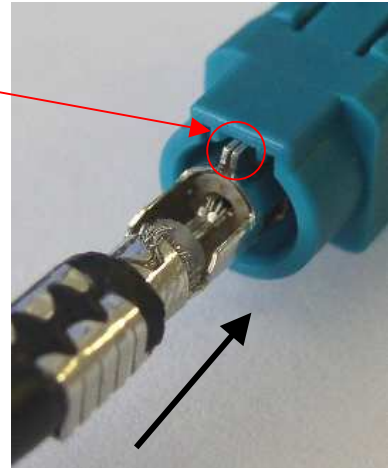

2

● **Push the connector into the housing until it clip on.**

● **Rotate the coax 180° into the housing to insure positioning.**

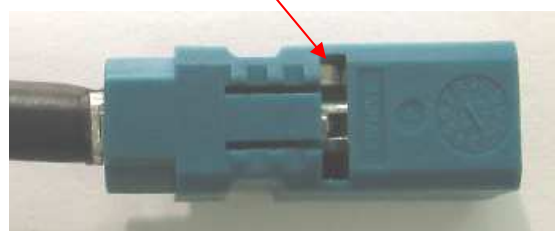
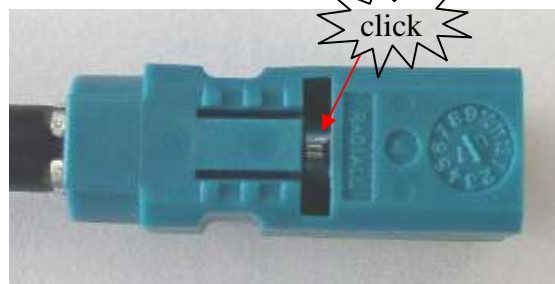
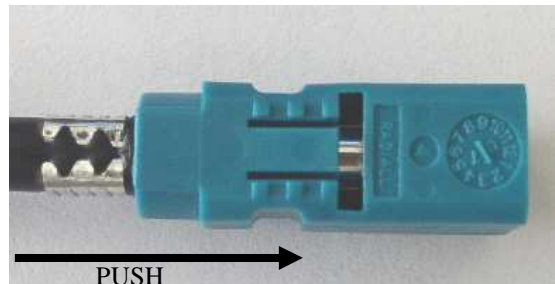

Issue : 1609 A

In the effort to improve our products, we reserve the right to make changes judged to be necessary.

R3C FEMALE HOUSING

R197.115._80

Series : SMB CARLOCK

RECOMMENDED DISASSEMBLING PROCEDURE

1

- To unlock the coax from the housing, rotate the coax until the tab is not in front of the elastic finger of the housing.
- insert a screw driver between the elastic finger and the slot of the housing as shown on the picture.
- Tip down the screw driver as shown on the picture to lift up the elastic finger until you have enough room.

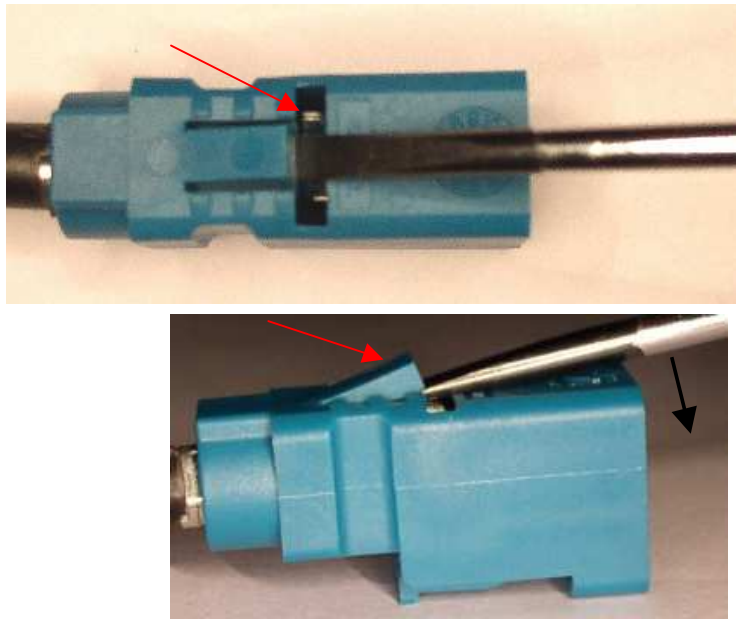

2

- Hold on the elastic finger up and rotate the coax until the tab is in front of the elastic finger of the housing. (you can use the crimping of the jacket as a reference).
- pull on the cable assembly to remove the coax from the housing.

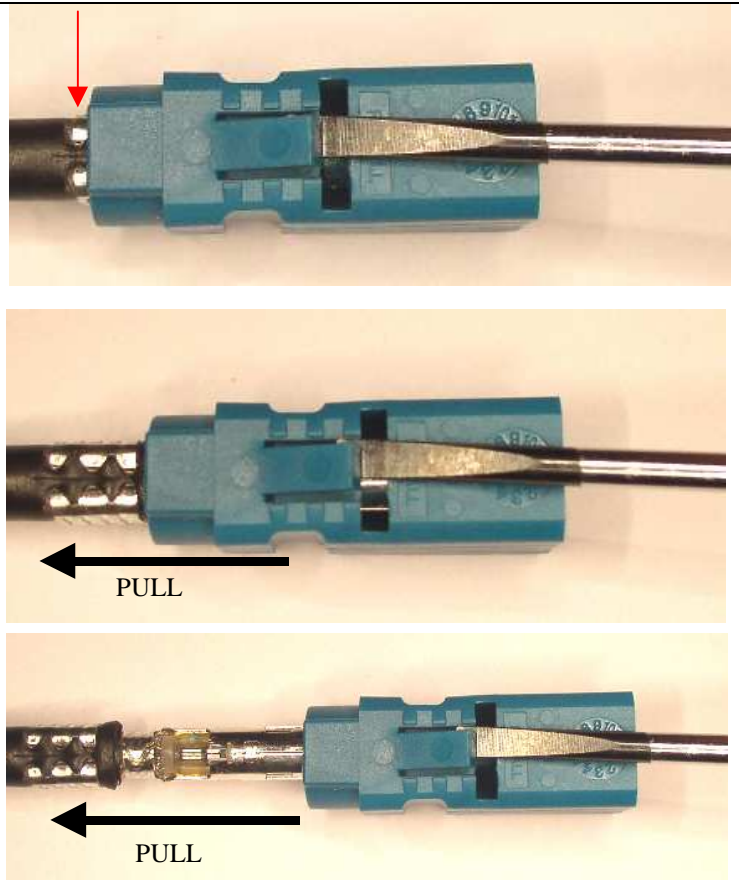

WARNING!
Do not use anymore the housing after removing it.