

R3C FEMALE COAX CAB 5/50

PACKAGING REEL 3000

R299.197.230

STANDARD CABLE

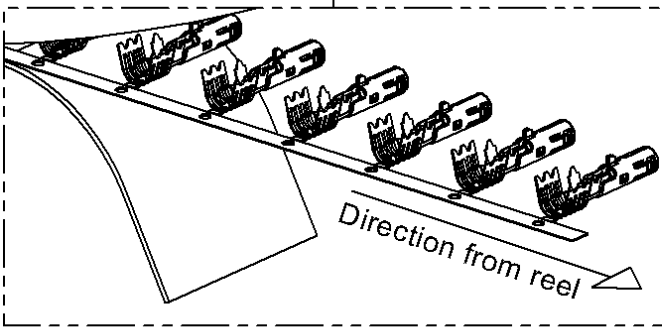
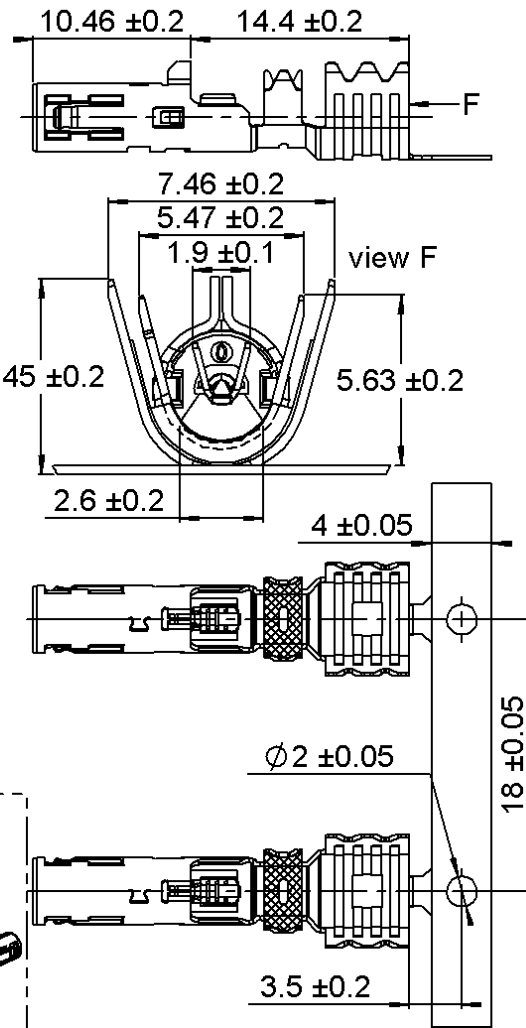
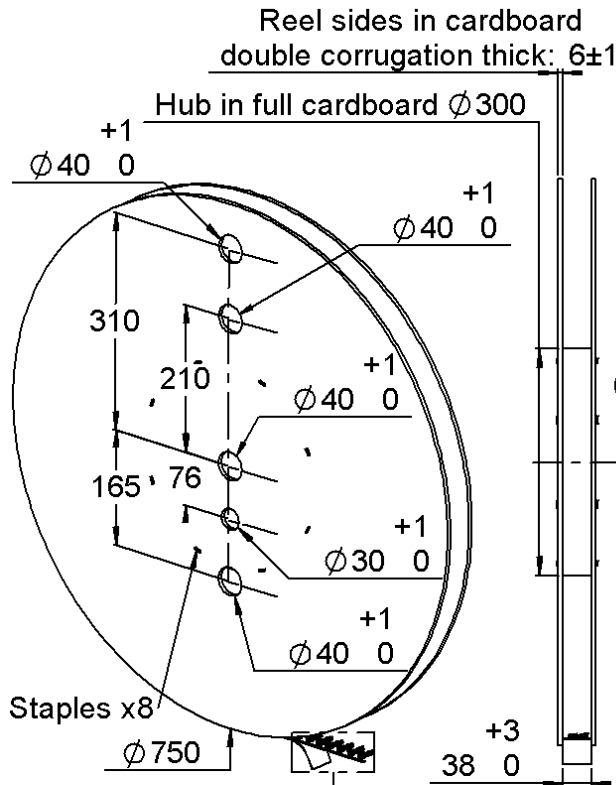

THIS COAX CAN BE USED WITH HOUSING R197.115_81 (replace the _ by the coding letter)

All dimensions are in mm.

COMPONENTS	MATERIALS	PLATING (µm)	
BODY	BRONZE	TIN 3 OVER NICKEL 2	
CENTER CONTACT	BRONZE	SELECTIVE GOLD+ SELECTIVE TIN	
OUTER CONTACT	-	UL CLASSIFICATION	COLOR
INSULATOR	POLYMER	UL94-V0	NATURAL
	-		
	-		

Standard Packaging : 3000+/-2%*

* Nota : possibility of having a maximum of five missing parts consecutively on the tape

Issue : 1408 D

In the effort to improve our products, we reserve the right to make changes judged to be necessary.



R3C FEMALE COAX CAB 5/50

R299.197.230

PACKAGING REEL 3000

STANDARD CABLE

Recommended stripping dimensions of the RG 58 cable for R3C female R299.197.230

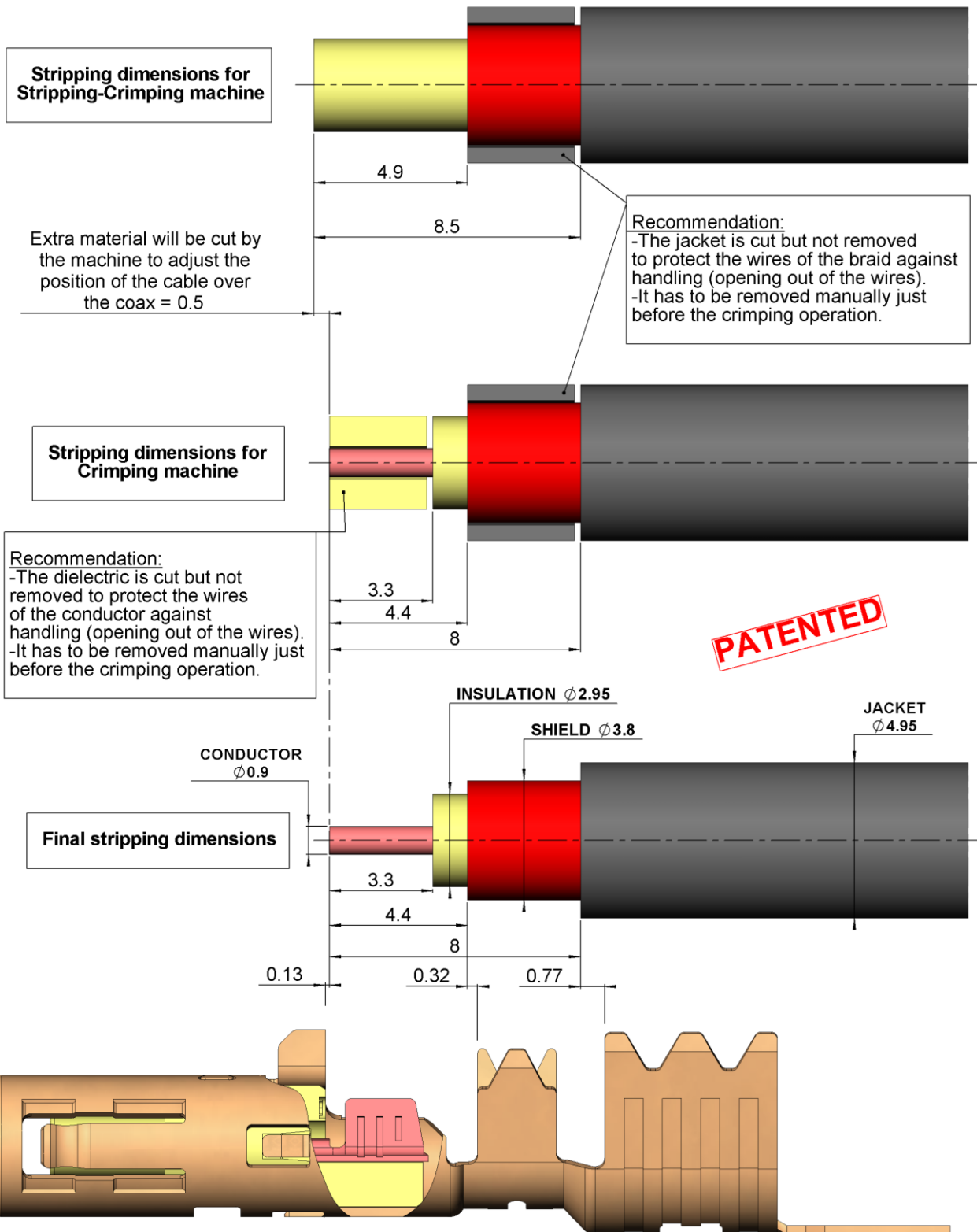

Issue : 1408 D

In the effort to improve our products, we reserve the right to make changes judged to be necessary.

R3C FEMALE COAX CAB 5/50

PACKAGING REEL 3000

R299.197.230

STANDARD CABLE

crimping height **				
Conductor type	conductor/body W	Conductor X	braid Y	jacket Z
stranded	2.7±0.05	1.18±0.05	3.7+0.05/-0.1	4,8+0.05/-0.1

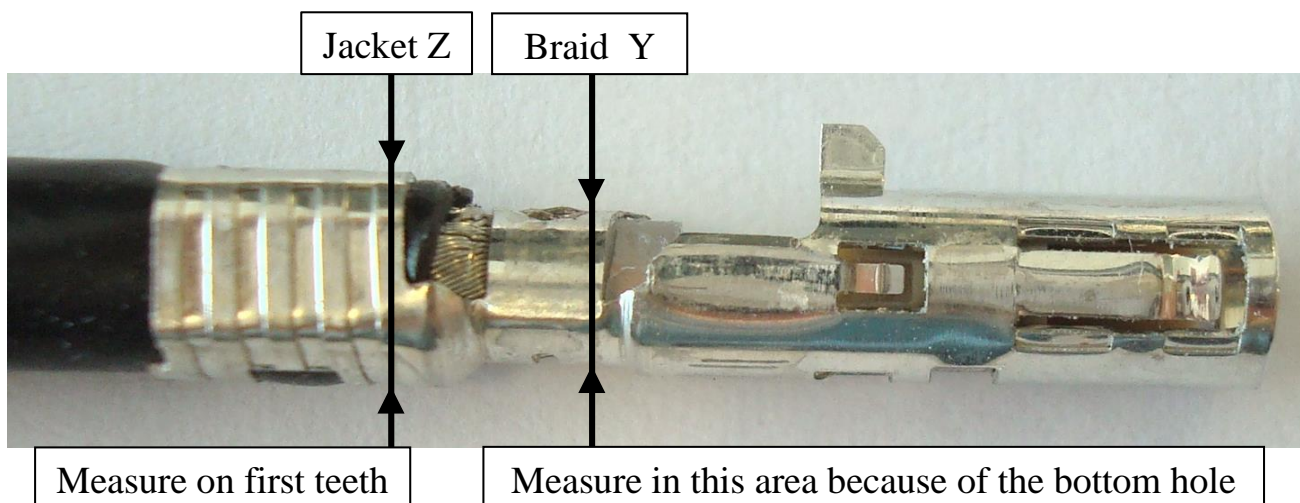
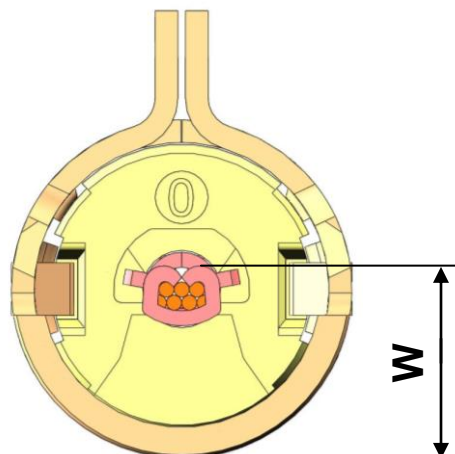
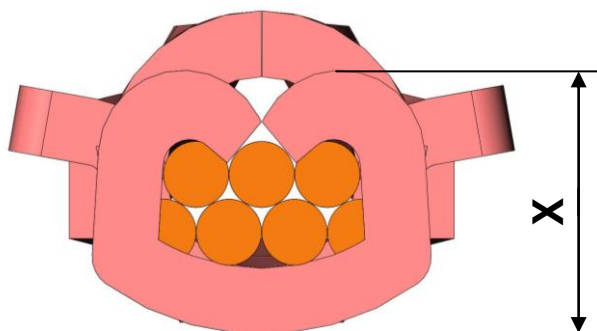

**** CAUTION**

- Before using applicator, make sure the press is calibrated :135,8 mm from the lower dead point up to the base
- Crimping height may change depending on the manufacturer of the cable, for more informations please contact us
- We recommend to make electrical test after each set up of the applicator:
 - Outer and center contact continuity+Dielectric withstanding voltage 800Vrms, 50Hz
 - Insulation resistance 1000 Mohms
 - Cable retention = 110Newton mini during 5 seconds with electrical continuity

Issue : 1408 D

In the effort to improve our products, we reserve the right to make changes judged to be necessary.

